

SONY®

Professional Flat Panel Displays

PFM Series

PFM-50C1*

PFM-42B2*

PFM-32C1*



* 32", 42", 50" viewable area, measured diagonally.

Sony breathes life into the Flat Panel Display.

Sony unveils a striking lineup of 16:9 Professional Flat Panel Displays. State-of-the-art technology enables these new models to deliver outstanding picture quality from slim, lightweight, flat panels.

The PlasmaPro™ PFM Series includes three models* : the 32-inch PFM-32C1*, with a resolution of 852 X 1024 pixels, the 42-inch PFM-42B2*, with a resolution of 1024 X 1024 pixels, and the 50-inch PFM-50C1*, with a resolution of 1365 x 768 pixels.

All three models include a range of versatile features for unsurpassed usability, and combine their superb performance with stylish design. The 32-inch and 50-inch include a stereo digital amplifier to power optional external loudspeakers.

These new PlasmaPro™ Flat Panel Displays are ideal for use in A/V presentations, for point of purchase/point of sale advertising in malls and airports, as background video monitors in restaurants and themed entertainment venues, and for many other space-limited applications where high-brightness, high-quality images are essential.

* 32", 42", 50" viewable area, measured diagonally.

PFM Series

PFM-50C1*50C1E

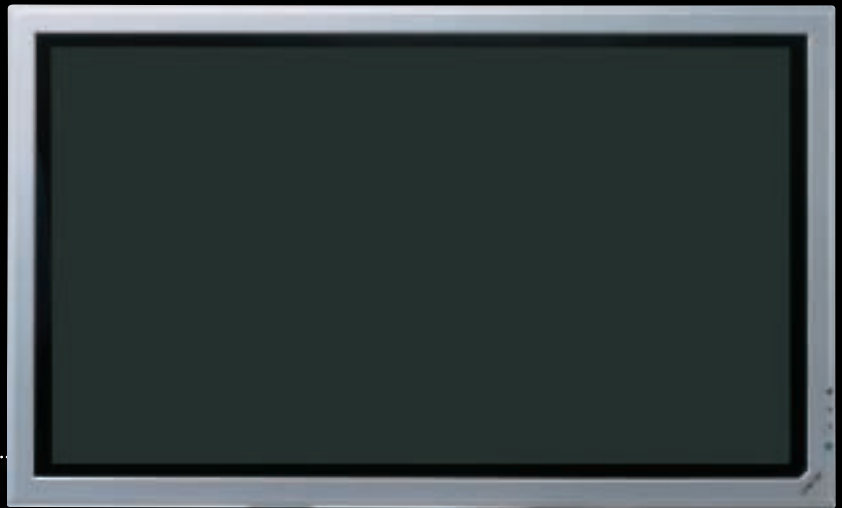

PFM-42B2*42B2F

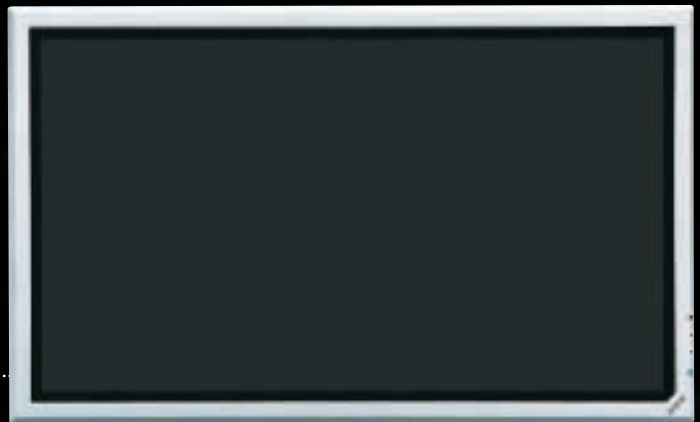

PFM-32C1*32C1E



The bezel of the PFM-42B2 has a color choice of warm silver and dark gray.
The bezels of the PFM-50C1 and PFM-32C1 are cool silver.
* 32", 42", 50" viewable area, measured diagonally.

Brilliant Picture Quality

Real Digital System

PFM 32 inch

PFM 50 inch

With the unique Sony digital signal processing technology of the Real Digital System, all signals are both input and processed digitally to give highly accurate image reproduction.

A new bi-pixel I/P (Interlace/Progressive) conversion circuit, developed exclusively for Sony flat panel displays, converts interlaced signals to progressive images. For film-originated sources, the Cinema Drive function (3-2 pull-down technology) is incorporated to help reproduce natural scene movement.

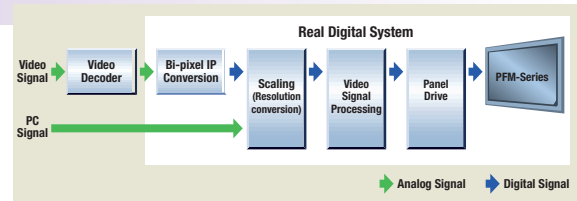

PFM 42 inch

*The PFM-42B2 delivers excellent, clear, smooth images thanks to the combination of its high-quality panel and Sony original I/P conversion technology.

Multi-Layer, AR-Coated, Protection panel

PFM 32 inch

PFM 42 inch

PFM 50 inch

The anti-reflection (AR) coating on the glass protection panel reduces light reflection for clear, high-contrast pictures.

Multiple Inputs and High-performance Scan Converter

PFM 32 inch

PFM 42 inch

PFM 50 inch

PFM Series displays utilize high-definition, 16:9 flat panels that provide smooth, high-quality images across the screen. They accept signals ranging from standard composite video to HDTV, DTV and RGB computer signals at up to UXGA resolution. A range of optional input adaptors are available, providing superb system flexibility. A built-in, high-performance scan converter offers optimum image quality whatever the signal format, providing accurate pixel-by-pixel image reproduction.

Versatile and stylish

PFM 32 inch

PFM 42 inch

PFM 50 inch

With their simple, yet sophisticated appearance, the PFM Series of displays offer a stylish, high impact, way to convey messages. A stylish bezel gives a sharp and sophisticated look that is right for any environment*. With excellent installation flexibility, these slim, lightweight displays provide large, superb quality images in minimal space.

*The bezel of the PFM-42B2 has a color choice between warm silver and dark gray.
*The bezels of the PFM-50C1 and PFM-32C1 are cool silver.

Network Capability (with the optional BKM-B30NW Adaptor)

PFM 42 inch

PFM 50 inch

The optional BKM-B30NW Network Adaptor provides an Ethernet 10Base-T/100Base-TX interface, plus a PC Card slot, to provide network connection for the PFM Series. Wired or wireless, these two PFM Series displays are ready to interface with the expanding world of visual network communications. This adaptor also provides a Y/C and a composite analog input.

• File sharing through a network

When these displays are connected to a network, files shared in that network can be retrieved and opened for display*.

* Microsoft PowerPoint® (PPT, PPS), Excel (XLS), JPEG, GIF, BMP and PNG files are supported.

• Remote control from networked PCs

Any PC within a network can communicate with the 42-inch or 50-inch viewable area, measured diagonally display via a web browser*. Operating presentations, organizing files and controlling both the display's functions and its setup parameters can all be done with a simple operation.

* System requirements
OS: Microsoft Windows® 98, Windows 98 SE, Windows or Windows 2000
Web browser: Internet Explorer 4.0 or later or Netscape Communicator 4.5x or 4.7x

■ WIRED

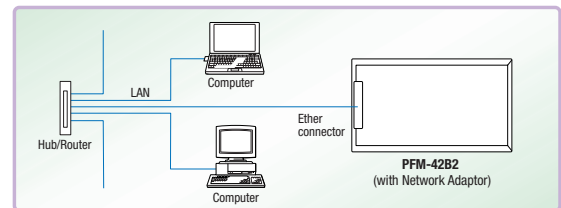

■ WIRELESS INFRASTRUCTURE

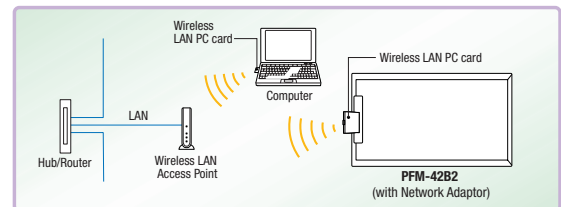

■ WIRELESS PEER TO PEER (Ad-hoc)

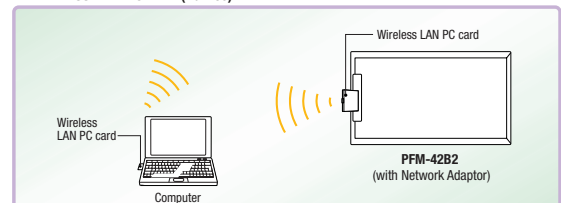

PFM 32 inch
PFM 42 inch
PFM 50 inch

NOTE: These icons indicate which features are available for each model.

High-quality Digital Audio Amplifiers

PFM
32
inch

PFM
50
inch

These two models incorporate high-quality digital amplifiers for clear audio reproduction. These amplifiers feed Speaker Out (L/R) connectors so that optional speakers can be connected to enhance the effectiveness and quality of presentations.

Other Features

- **Choice of remote control operation**

Operational functions can be controlled from the supplied remote control unit* or via RS-232C.

*RM-971 for the PFM-32C1 and PFM-50C1, RM-42B for the PFM-42B2

PFM
32
inch

PFM
50
inch

PFM
42
inch

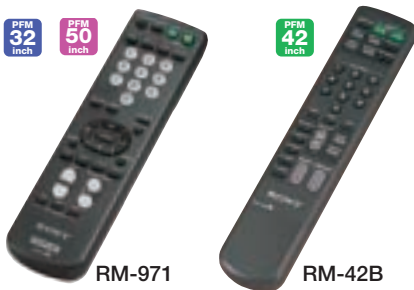

RM-971

RM-42B

- **Mounting freedom**

All models can be mounted horizontally or vertically, fixed on an optional stand, on a wall or hung from the ceiling.

- **Picture Mode function**

Three user presets and two fixed sets of display parameters are available.

- **Selectable aspect ratio**

Aspect ratios for Widescreen 16:9, Wide Zoom, Letter Box Zoom or Standard 4:3 displays are selectable.

- **Choice of color temperature setting**

Up to three color temperature setting can be registered with the PFM-32C1 and PFM-50C1, and up to six settings with the PFM-42B2.

- **Size control**

Picture size can be adjusted both vertically and horizontally.

- **Shift control**

The center of the picture can be adjusted both vertically and horizontally.

- **Picture zoom**

A section of the picture can be zoomed in for a closer look. This feature also allows up to 4x4 units to be used in video wall applications.

- **Auto Wide function**

The Auto Wide function automatically enlarges the video image to fill the 16:9 wide screen

- **Dot phase adjustment**

This function optimizes the scan converter sampling phase to the input signal.

- **Memory save/load**

Stores up to twenty picture settings.

- **Six-language on-screen display**

Quick and simple setup in English, French, German, Italian, Spanish and Japanese.

- **Closed Caption decoder**

- **Screen Saver functions**

Picture Orbiting mode and Picture Inversion mode can be selected.

- **Power Saving function**

- **24-hour on/off timer**

- **Worldwide power supply range**

PFM
32
inch

PFM
50
inch

Flat Panel Advantages

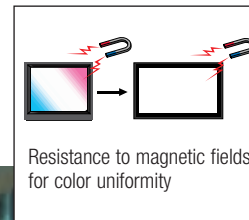
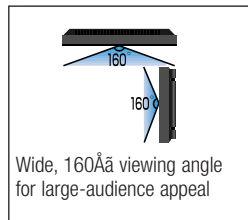
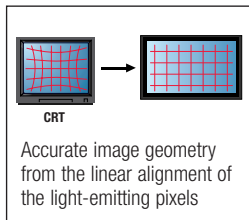
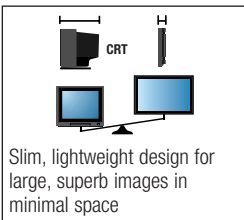

The Sony PFM range adopts Plasma Display Panels (PDP). The versatility and flexibility of PDP technology is ideal for many applications.



Optional Accessories



PFM 42 inch
**Component Video Input Adaptor
 BKM-B12**

- Analog component input (pin jack)
- Control-S input/output

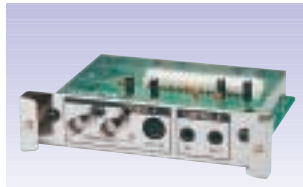

PFM 42 inch
**Composite Video Input and Control S Adaptor
 BKM-B13**

- Composite input/output
- Y/C input
- Control-S input/output



PFM 42 inch **PFM 50 inch**
**Network Adaptor
 BKM-B30NW**

- Y/C input
- Analog composite input (pin jack)
- Ethernet 10Base-T/100Base-TX interface
- PC Card slot Type II
- USB port (A type) (x 2)

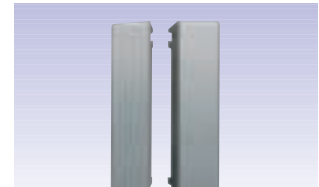

PFM 32 inch **PFM 50 inch**
**Speaker System
 SS-SP10A**

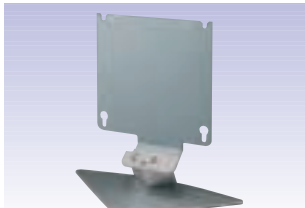

PFM 32 inch
**Monitor Stand
 SU-P32C**

This picture shows SU-P32C.



PFM 42 inch
**Monitor Stand
 SU-42B**

PFM 50 inch
**Monitor Stand
 SU-P50C**

Connector Panel

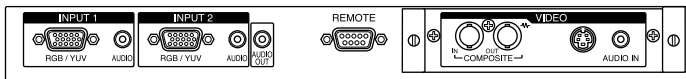

PFM-42B2

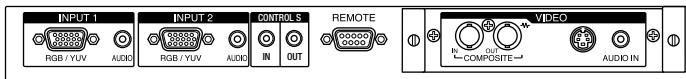

PFM-32C1 and PFM-50C1

Control Panel

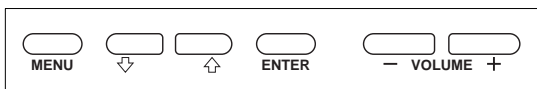

PFM 32 inch **PFM 50 inch** The control panel is located on the top of the unit.

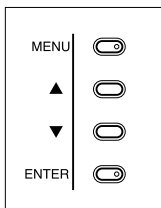

PFM 42 inch The control panel is located on the rear of the unit.

Note:
 The power switch is equipped on the front of the display.

Dimensions

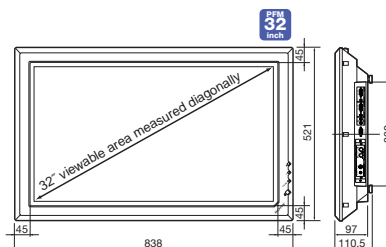
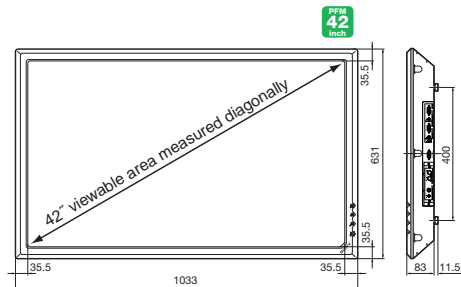
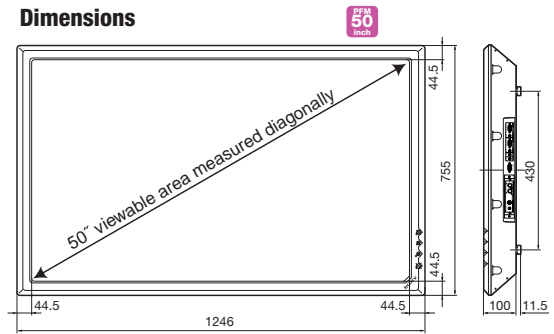

Specifications

Picture Performance		PFM32C1/32C1E	PFM42B2/42B2E	PFM50C1/50C1E
Panel	Resolution	852 x 1024 pixels	1024 x 1024 pixels	1365 x 768 pixels
	Pixel pitch	0.84 x 0.39 mm	0.90 x 0.51 mm	0.81 x 0.81 mm
	Active area (W/H)	715.68 x 399.36 mm	921.60 x 522.24 mm	1106 x 622 mm
	Viewable area	32-inch/820 mm (measured diagonally)	42-inch/1,058 mm (measured diagonally)	50-inch/1270 mm (measured diagonally)
	Colors	16.8 million colors simultaneously		
Type	AC-type Plasma Display Panel with anti-reflection screen			
Color system	NTSC, PAL, SECAM, NTSC4.43, PAL-M, PAL 60, PAL-N		NTSC, PAL, SECAM, NTSC4.43, PAL-M, PAL 60	NTSC, PAL, SECAM, NTSC4.43, PAL-M, PAL 60, PAL-N
Sampling rate			13.5 to 140 MHz	
Input/Output				
INPUT1/INPUT2		D-sub 15-pin		
	RGB	0.714 Vp-p/non-composite, 1.0 Vp-p/composite, 75 Ω		
	YUV	0.7 Vp-p/non-composite (U/V), 1.0 Vp-p/composite (Y), 75 Ω		
	AUDIO	Stereo mini jack, 500 mV rms, high impedance		
VIDEO	COMPOSITE IN	BNC, 1.0 Vp-p ±2 dB sync negative, 75 Ω automatic termination		
	Y/C IN	Mini DIN 4-pin		
	Y	1.0 Vp-p ±2 dB sync negative, 75 Ω		
	C	0.286 Vp-p ±2 dB sync negative (NTSC), 75 Ω		
		0.3 Vp-p ±2 dB sync negative (PAL), 75 Ω		
	AUDIO IN	Stereo mini jack, 500 mV rms, high impedance		
	COMPOSITE OUT	Loop-through BNC		
CONTROL S IN/OUT	Stereo mini jack, 5.0 Vp-p		Stereo mini jack, 5.0 Vp-p	
REMOTE (RS-232C)	D-sub 9-pin			
Audio OUT			Stereo mini jack, 500 mV rms, high impedance	
SPEAKER OUT (L/R)	7 W + 7 W (impedance: 6 Ω)		7 W + 7 W (impedance: 6 Ω)	
General				
Power requirements	AC 100 to 240 V, 50/60 Hz, 3.2 to 1.6 A		AC 100 to 240 V, 50/60 Hz, 4.5 to 1.8 A	
Power consumption	270 W		360 W	
Operating temperature	0 to 35 °C (32 to 95 °F)			
Storage temperature	-10 to 40 °C (14 to 104 °F)			
Humidity	20 to 90 %, no condensation			
Dimensions* (W/H/D)	33 x 20 5/8 x 3 7/8 inches (838 x 521 x 97 mm)		40 3/4 x 24 7/8 x 3 3/8 inches (1033 x 631 x 83 mm)	
Weight	48 lb 8 oz (22 kg)		62 lb 9 oz (28.4 kg)	
Supplied Accessories				
AC Power Cord, AC Plug Holder (2), AA size Battery (2), Cable Holder A (2), Cable Holder B (4), Operating Instructions				
Remote Commander RM-971		Remote Commander RM-42B		Remote Commander RM-971
Regulation Compliance				
UL1950, CSA No.950 (c-UL), CE LVD (EN60950), FCC Class B, IC Class B, VCCI Class B, CE EMC (EN55022 Class-B, EN55024, EN61000-3-2, EN61000-3-3), C-Tick (AS/NZS 3548/95, AS/NZS 4252.1), CCIB, JEIDA, CB, KTL, MIC				

*Excluding protruding parts.

Preset Signals

VIDEO	fH (kHz)	Frame rate* (Hz)	Resolution (Active)
NTSC	15.734	60	480 lines
PAL	15.625	50	575 lines
SECAM	15.625	50	575 lines
NTSC _{4.43}	15.734	60	480 lines
PAL60	15.734	60	480 lines
PAL-M	15.734	60	480 lines
PAL-N ²	15.734	60	480 lines
575/50I	15.625	50	575 lines
480/60I	15.734	60	480 lines
1080/24PsF	27.000	24	1080 lines
1080/50I	28.125	50	1080 lines
576/50P	31.250	50	576 lines
480/60P	31.469	60	480 lines
1080/60I	33.750	60	1080 lines
720/60P	45.000	60	720 lines
COMPUTER INPUT	fH (kHz)	fV (Hz)	Resolution (Active)
VGA-1 (VGA 350)	31.5	70.1	640 x 480 dots
640 x 350 @85 (VESA STD)	37.9	85.1	640 x 350 dots
640 x 400 @85 (VESA STD)	37.9	85.1	640 x 400 dots
640 x 480 @60 (VESA STD)	31.5	59.9	640 x 480 dots
Mac 13"	35.0	66.7	640 x 480 dots
640 x 480 @72 (VESA STD)	37.9	72.8	640 x 480 dots
640 x 480 @75 (VESA STD)	37.5	75.0	640 x 480 dots
640 x 480 @85 (VESA STD)	43.3	85.0	640 x 480 dots
852 x 480 @60 (I-O DATA) ³	31.7	60.0	852 x 480 dots

VGA (VGA TEXT)	31.5	70.1	720 x 400 dots
720 x 400 @85 (VESA STD)	37.9	85.0	720 x 400 dots
800 x 600 @56 (VESA STD)	35.2	56.3	800 x 600 dots
800 x 600 @60 (VESA STD)	37.9	60.3	800 x 600 dots
800 x 600 @72 (VESA STD)	48.1	72.2	800 x 600 dots
800 x 600 @75 (VESA STD)	46.9	75.0	800 x 600 dots
800 x 600 @85 (VESA STD)	53.7	85.1	800 x 600 dots
Mac 16"	49.7	74.6	832 x 624 dots
1024 x 768 @60 (VESA STD)	48.4	60.0	1024 x 768 dots
1024 x 768 @70 (VESA STD)	56.5	70.1	1024 x 768 dots
1024 x 768 @75 (VESA STD)	60.0	75.0	1024 x 768 dots
1024 x 768 @85 (VESA STD)	68.7	85.0	1024 x 768 dots
1152 x 864 @75 (VESA STD)	67.5	75.0	1152 x 864 dots
Mac 21"	68.7	75.1	1152 x 870 dots
1280 x 960 @60 (VESA STD)	60.0	60.0	1280 x 960 dots
1280 x 960 @85 (VESA STD)	85.9	85.0	1280 x 960 dots
1280 x 1024 @60 (VESA STD)	64.0	60.0	1280 x 1024 dots
1280 x 1024 @75 (VESA STD)	80.0	75.0	1280 x 1024 dots
1280 x 1024 @85 (VESA STD) ^{4*}	91.1	85.0	1280 x 1024 dots
1600 x 1200 @60 (VESA STD) ^{5*}	75.0	60.0	1600 x 1200 dots
856 x 480 @60 (Matrox) ^{6*}	30.2	60.0	856 x 480 dots
856 x 480 @59.6 (Matrox) ^{6*}	30.1	59.6	856 x 480 dots
856 x 480 @60.1 (Matrox) ^{6*}	30.1	60.1	856 x 480 dots

*1 Compatible with 1/1,001.

*2 Acceptable to the PFM-32C1 and PFM-50C1

*3 With the graphic accelerator board of I-O DATA DEVICE, INC.

*4 Acceptable to the PFM-42B1 and PFM-50C1

*5 Dot phase adjustment not applicable to UXGA (1600 x 1200).

*6 With the graphic card by Matrox Graphics Inc.

SONY

Sony Electronics Inc.
One Sony Drive
Park Ridge, NJ 07656
www.sony.com/displaysystems

©2002 Sony Electronics Inc. All rights reserved.

Reproduction in whole or in part without permission is prohibited.

Features and specifications are subject to change without notice.

All non-metric weights and measures are approximate.

Sony and PlasmaPro™ are trademarks of Sony.

PowerPoint and Windows are registered trademarks of Microsoft Corporation.

Netscape is a registered trademark of Netscape Communications Corporation.

PLASMA
MONITORS  PRO

DI-0035

MK7819V1OHB02MAR

Printed in USA (5/02)